

USER MANUAL

Part & Function

HAX-600

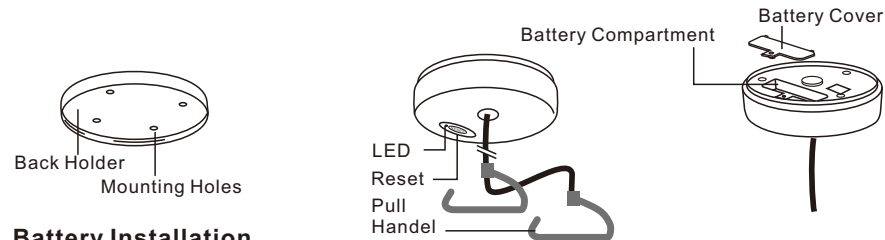

Battery Installation

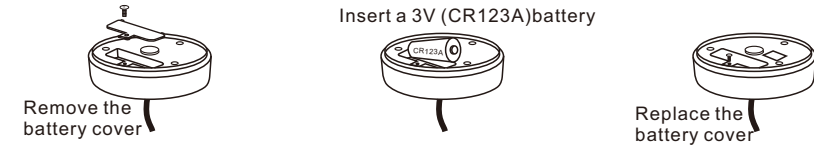

The toilet pull works with the receiver (chime) and must be paired before using

Step 1: Insert battery to the sensor.

Step 2: Insert batteries to the receiver (chime).

Step 3: Enter pairing mode for receiver (chime unit).

Press and hold the ● zone selector button 3 seconds. The LED #1 will flash.

Step 4: Press the ● button again to move to the zone you want to pair with.

Press ↻ melody selector to scroll through the melodies. Once you hear your preferred melody, do not press again as it is now selected.

Step 5: Once you have selected the zone and melody, trigger the toilet pull by pull the handle.

If successful, the receiver will generate a short tone. Press the ● button to exit pairing mode, the system is now ready to use.

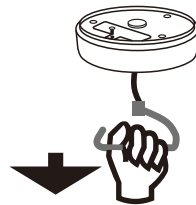
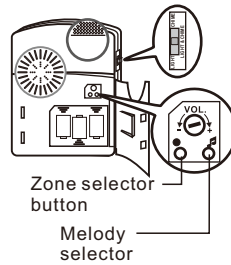

Installation

Requires an electric drill for holes to fix the Sensor with the provided ram plug and screws.

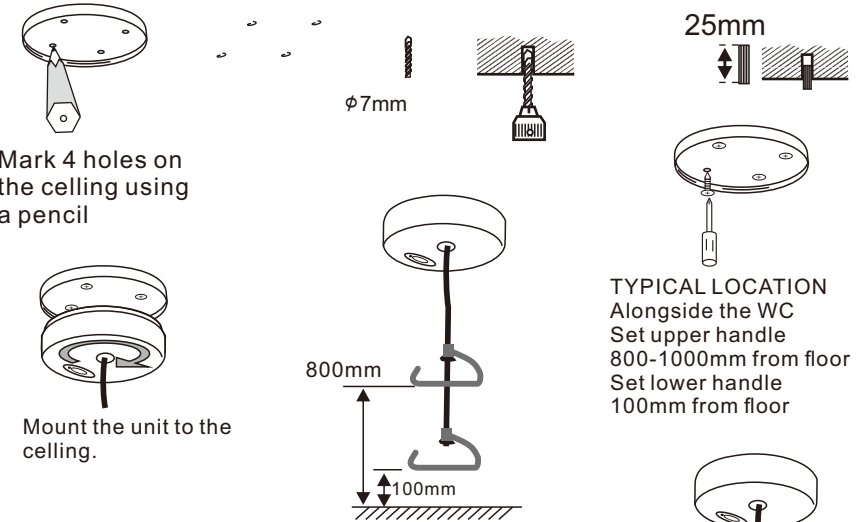

Test the Sensor

Pull the handle to test the toilet pull after installation. The LED on the toilet pull will lit up 1.2 second to indicate it is transmitting.

The unit will keep transmission every 1.3 seconds until release the handle.

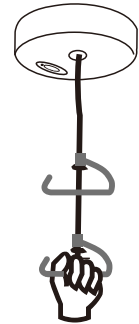

FCC Statement:

This equipment has been tested and found to comply with the limits for a Class B digital device, pursuant to part 15 of the FCC Rules. These limits are designed to provide reasonable protection against harmful interference in a residential installation. This equipment generates, uses and can radiate radio frequency energy and, if not installed and used in accordance with the instructions, may cause harmful interference to radio communications. However, there is no guarantee that interference will not occur in a particular installation. If this equipment does cause harmful interference to radio or television reception, which can be determined by turning the equipment off and on, the user is encouraged to try to correct the interference by one or more of the following measures:

- * Reorient or relocate the receiving antenna.
- * Increase the separation between the equipment and receiver.
- * Connect the equipment to an outlet on a circuit different from that to which the receiver is connected.

This device complies with part 15 of the FCC rules. Operation is subject to the following two conditions: (1) This device may not cause harmful interference, and (2) this device must accept any interference received, including interference that may cause undesired operation.

Note: Modifications to this product will void the user's authority to operate this equipment.



RoHS

R&TTE

